

# Fluid100

## PORTABLE FLUID TEMPERATURE CALIBRATOR



**Operating range:**  
-12 °C / +125 °C (\*)

**Applications:**

- Check and calibration of temperature sensor in the laboratory as well as in the field in compliance of ISO 9000 regulations.
- Check of glass thermometers.
- Check of thermostats.



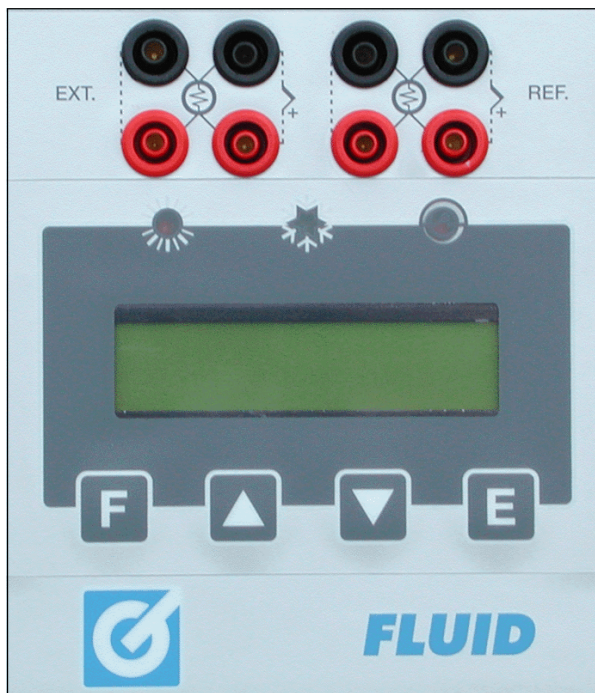

# Fluid100

## PORTABLE FLUID TEMPERATURE CALIBRATOR

**FLUID100** is a portable thermostatic calibrator used for checking thermocouples and PT100 in the laboratory as well as in the field. It consists of an aluminium vessel whose capacity is about 400 cc and it is constantly kept homogenous by a magnetic mixer whose speed is adjustable according to the viscosity of the fluid used.

The **FLUID100** oven doesn't use external refrigerating liquids; the internal tank is heated and cooled by Peltier elements.

The mixing process ensures a proper heat transmission and excellent stability and uniformity values; the large size of the input mouth makes it possible to test sensors of various lengths and diameters.

**FLUID100** is equipped with a new PID microprocessor controller with a resolution up to 0,01 °C, setting of the standard of measurement in °C, °F e K, programming of ascent/descent ramps and storage of the thermostats' operative temperature.

In the **FLUID100-2I** version, the instrument is equipped with an acquisition card having two adjustable inputs (Pt100 3/4 wires; thermocouples: J, K, N, R, S) with bushes fitted with gold-plated contacts and automatic compensation of the cold junction.

The first input is provided for the reference sample probe, thus obtaining a complete calibration system which can be certified by S.I.T. centres, in compliance with ISO 9000 regulations.

The second input is provided for probes that are being tested; hence, the instrument can display the temperature of the well, the temperature of the sensor to be checked and of the reference sample probe, at the same time.

Furthermore, **FLUID100** is equipped with the RS232 serial interface; it can operate in automatic mode connected to the PC by means of the AQ2sp software which enables to carry out probe calibrations, thermostats test and cyclical life tests; test results can be stored and printed, so they are easily traceable in compliance with ISO 9000 standards.

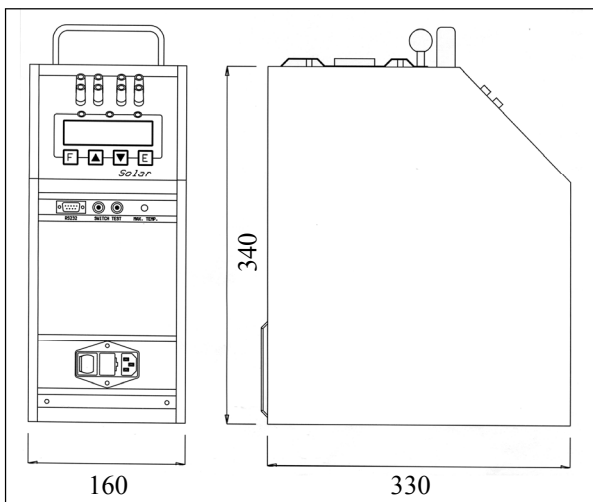

### TECHNICAL DATA (FLUID100-00 - basic version)

Operating range:	-12 °C ÷ +125 °C (*)
Stability:	±0,02 °C (@ -5 °C)
Uniformity (@ 0 °C)	
- Radial	±0,04 °C (@ 50 mm)
- Axial	±0,05 °C (for 60 mm from the bottom)
Mean heating time:	12 °C/min
Mean cooling time:	5 °C/min
Display resolution:	0,1 °C / 0,01 °C
Display accuracy:	±0,15 °C
Units of measurement:	°C - °F - K
Serial interface:	RS232
Well diameter:	54 mm
Usable well depth:	150 mm
Power supply:	115 or 230 V - 50/60 Hz
Electric power:	300 VA
Calibrator size:	160 x 340 x 330 mm
Calibrator weight:	8 kg

(\*) Room temperature 20 °C

### FLUID100-2I

Version with data acquisition card and two input devices to measure:

Type of probe	Range	Accuracy
Pt100 IEC 3/4 wires	-100 / 700 °C	±0,3 °C
Thermocouple J	0 / 1000 °C	±1 °C
Thermocouples K N R S	0 / 1300 °C	±1 °C

### STANDARD EQUIPMENT: (code: FLUID100-00)

- FLUID100 calibrator.
- Bottle (500 cc) of silicon oil 200C5.
- Closing top used for transport.
- Fluid emptying system.
- Support for glass thermometers.
- Power supply cable.
- Fuses kit.
- Thermostat connection cables.
- Test report.
- Instruction manual.
- RS232 serial interface.
- Cordura® soft bag.
- Kit of clamp connections (only 2I version).

### ACCESSORIES ON DEMAND:

- AQ2sp software.
- Pt100 sample probe.
- RS232 serial cable.
- USB/RS232 converter.
- S.I.T. certificate (only 2I version) performed by a sample probe connected to FLUID100.

### HOW TO ORDER:

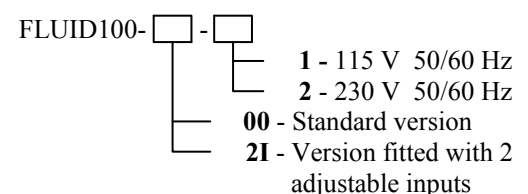

**GIUSSANI S.r.l.**  
Via dei Crederi, 411  
24045 Fara Gera d'Adda (BG) - Italy  
Tel.: 0363/399019 - Fax.: 0363/398725  
[www.giussanionline.it](http://www.giussanionline.it)  
E-mail: [info@giussanionline.it](mailto:info@giussanionline.it)



### CERTIFICATION:

All instruments are supplied with final testing, stability and accuracy certification traceable to S.I.T. standards.

### A QUESTION OF CALIBRATION